

# DWA 1100

## TRUCK TROLLEY

*INNOVATIVE MOBILE*  
TRUCK WHEEL  
ALIGNMENT SYSTEM

**NEW**



# CEMB

GARAGE EQUIPMENT



# DWA 1100

# TRUCK TROLLEY

**COMPACT AND WIRELESS SYSTEM** consisting of a mobile support for sensors and clamps, which acts as a recharge point for the CCDs and the toughpad

**TOUGHPAD 10"** with Wi-Fi connection that can also be used when carrying out operations under the vehicle. It eliminates the need of a bulky PC and guarantees greater ease of use

**MOBILE STRUCTURE ON WHEELS** to work comfortably on board the vehicle; also ideal for multi-bay workshops. No space problems

100 mm diameter **PIVOTING AND RUBBER WHEELS** to allow smooth movement on any type of flooring. The addition of brakes on two of the wheels prevents accidental movement of the trolley during work operations

**SISTEMA COMPATTO E WIRELESS** composto da un supporto mobile per sensori e aggrappi, che funge da ricarica dei CCD e del toughpad **TOUGHPAD 10"** con connessione Wi-Fi utilizzabile anche quando si effettuano operazioni sottoscocca. Elimina l'ingombro del pc e garantisce una maggiore praticità di utilizzo

**STRUTTURA MOBILE CARRELLATA** per lavorare comodamente a bordo veicolo; ideale anche per officine multibay. Nessun problema di spazio

**RUOTE PIVOTANTI E GOMMATE** da 100 mm di diametro permettono una movimentazione fluida su qualsiasi tipo di pavimentazione. L'aggiunta di freni su due delle ruote evita lo spostamento accidentale del carrello durante le operazioni di lavoro

**SYSTÈME COMPACT ET SANS FIL** composé d'un support mobile pour détecteurs et griffes, qui sert de recharge pour les CCD et le toughpad **TOUGHPAD 10"** avec connexion Wi-Fi pouvant également être utilisée pour effectuer des opérations sous le véhicule. Elle élimine l'encombrement du PC et garantit une plus grande facilité d'utilisation

**STRUCTURE MOBILE SUR ROUES** pour travailler confortablement à bord du véhicule; également idéal pour les garages multibay. Pas de problème d'espace

Les **ROUES PIVOTANTES ET CAOUTCHOUTÉES** de 100 mm de diamètre permettent un mouvement fluide sur tout type de sol. L'ajout de freins sur deux des roues évite le déplacement accidentel du chariot pendant les opérations de travail

**KOMPAKTES, KABELLOSES SYSTEM** mit beweglicher Ablage für Messköpfe und Radklammer, die gleichzeitig als CCD- und Toughpad-Ladestation dient **TOUGHPAD 10"** mit WLAN-Anschluss, das auch für Arbeiten unter dem Fahrzeug verwendet werden kann. Macht den platzraubenden PC überflüssig und gewährleistet einen höheren Bedienkomfort

**FAHRBARER AUFBAU** für ein bequemes Arbeiten am Fahrzeug ohne Platzprobleme; auch ideal für multibay Werkstätten

**GUMMIERTE LENKRÄDER** mit einem Durchmesser von 100 mm ermöglichen ein problemloses Verfahren auf jeder Art von Bodenbelag. Die Hinzufügung von Bremsen an zwei der Räder verhindert ein versehentliches Bewegen des Wagens während der Arbeitsvorgänge

**SISTEMA COMPACTO E INALÁMBRICO** formado por un soporte móvil para captadores y abrazaderas, que sirve como cargador de CCD y toughpad **TOUGHPAD de 10"** con conexión Wi-Fi que también puede utilizarse para realizar operaciones debajo del vehículo. Elimina el estorbo del PC y garantiza una mayor practicidad de uso

**ESTRUCTURA MÓVIL CON RUEDAS** para trabajar cómodamente a bordo del vehículo; también ideal para talleres multibay. Sin problemas de espacio

Las **RUEDAS PIVOTANTES Y ENGOMADAS** de 100 mm de diámetro permiten un movimiento suave en cualquier tipo de suelo. La adición de frenos en dos de las ruedas evita el desplazamiento accidental del carrito durante las operaciones de trabajo

## SOFTWARE



**Adjust two axles in one screen**

Regolazione di entrambi gli assi in un'unica schermata

Réglage des deux essieux sur une unique page

Einstellung beider Achse in einem einzigen Bildschirm

Ajuste de ambos los ejes en una única pantalla

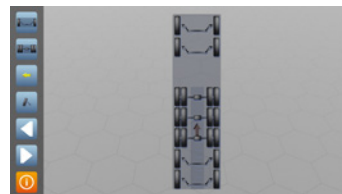

**Step by step procedure up to 7 axles**

Procedura guidata fino a 7 assi

Procédure pas à pas jusqu'à 7 essieux

Schritt für Schritt-Verfahren bis zu 7 Achsen

Procedimiento pilotado hasta 7 ejes



**2 measuring heads mode Quick measurement of front axle**

Modalità a due sensori Misurazione rapida dell'asse anteriore

Mode deux capteurs Mesure rapide de l'essieu avant

Zwei-Sensoren Modus Schnelle Messung der Vorderachse

Modalidad 2 sensores Medición rápida del eje anterior



**AUDIT function for the identification of driving problems**





Funzione AUDIT per la diagnosi completa dei disturbi di guida

Fonction AUDIT pour l'identification des problèmes de conduite

Funktion AUDIT für die Diagnose der Fahrstörungen

Función AUDIT para la identificación de problemas de conducción

## RUGGED TOUGHPAD





-  HD 10" touch screen - Windows 10 operating system - Fast operation speed - It supports WiFi, Bluetooth, HDMI. Dustproof, waterproof, breakingproof
-  Display touch HD da 10" - Sistema operativo Windows 10 - Rapidità delle operazioni - Supporta WiFi, Bluetooth, HDMI. Antipolvere, impermeabile, a prova di rottura
-  Écran tactile HD 10" - Système d'exploitation Windows 10 - Vitesse rapide de fonctionnement - Il prend en charge WiFi, Bluetooth, HDMI. Antipoussière, étanche, incassable
-  HD-10-Zoll-Touchscreen - Betriebssystem Windows 10 - Schnelle Betriebsgeschwindigkeit - Unterstützt WLAN, Bluetooth, HDMI. Staubdicht, wasserdicht, bruchsicher
-  Pantalla táctil HD de 10" - Sistema operativo Windows 10 - Velocidad de operación rápida - Soporta WiFi, Bluetooth, HDMI. A prueba de polvo, impermeable, a prueba de roturas

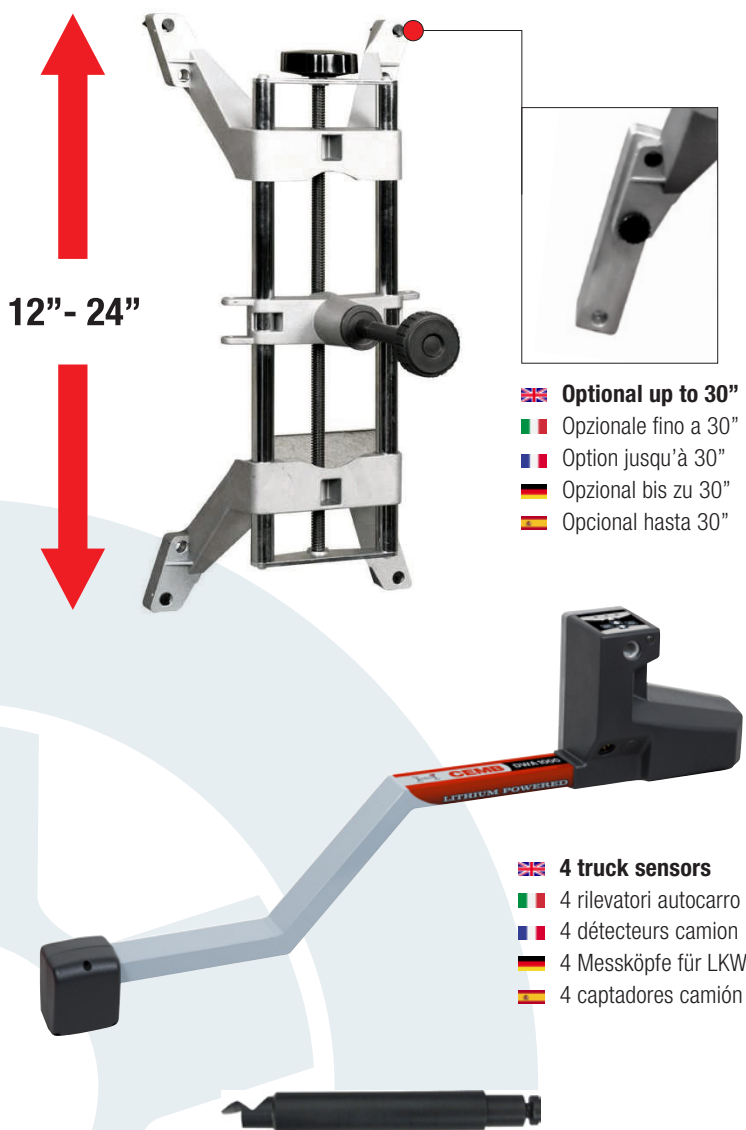

## STANDARD CONFIGURATION







12" - 24"

-  **Optional up to 30"**
-  Opzionale fino a 30"
-  Option jusqu'à 30"
-  Opzional bis zu 30"
-  Opcional hasta 30"

-  **4 truck sensors**
-  4 rilevatori autocarro
-  4 détecteurs camion
-  4 Messköpfe für LKW
-  4 captadores camión



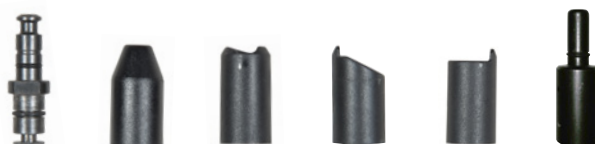
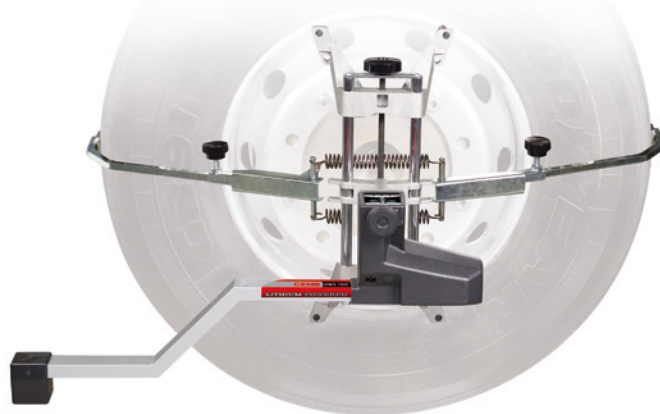

### **Metal 120 mm universal grips, with reference surface, for truck and bus wheels**

-  Unghiette universali 120 mm, con piano di riferimento, per ruote di autocarro e bus
-  Onglets universels 120 mm en métal, avec surface de référence, pour roues de camion et de bus
-  Universal-Radklammerfingern aus Metall 120 mm, mit Auflageoberfläche, für Räder von LKWs und Bussen
-  Uñas universales 120 mm en metal, con superficie de referimiento, para ruedas de camión y bus

## OPTIONAL ACCESSORIES







### **Clamp supporting arms and set of tips for tyres with external diameter up to 50"**

-  Bracci e gruppo di puntali per aggrappo in appoggio a pneumatici con diametro esterno fino a 50"
-  Bras et groupe de broches pour griffe en appui sur des pneus ayant un diamètre externe jusqu'à 50"
-  Klemmarme und Positionsfinger für Radklammern zum Auflegen auf Reifen mit Aussendurchmesser bis zu 50"
-  Brazos y grupo de puntales para mordaza en apoyo a neumáticos con diámetro externo hasta 50"

## GRIPS FOR ALL RIMS AND TYRES ARE AVAILABLE



### **Metal grips for clamping on steel rims from the inside**

-  Unghiette in metallo per aggrappo dall'interno su cerchi in ferro
-  Onglets en métal pour accrochage de l'intérieur sur jantes en fer
-  Metallkrallen zum Halten von innen bei Eisenfelgen
-  Uñas en metal para mordaza desde el interior en llantas en hierro

