

# DWA 1100 HYBRID

REVOLUTIONARY  
COMBINED  
CAR-TRUCK  
ALIGNMENT  
SYSTEM



# CEMB

# DWA 1100 HYBRID

## SWITCH AND TILT HEADS

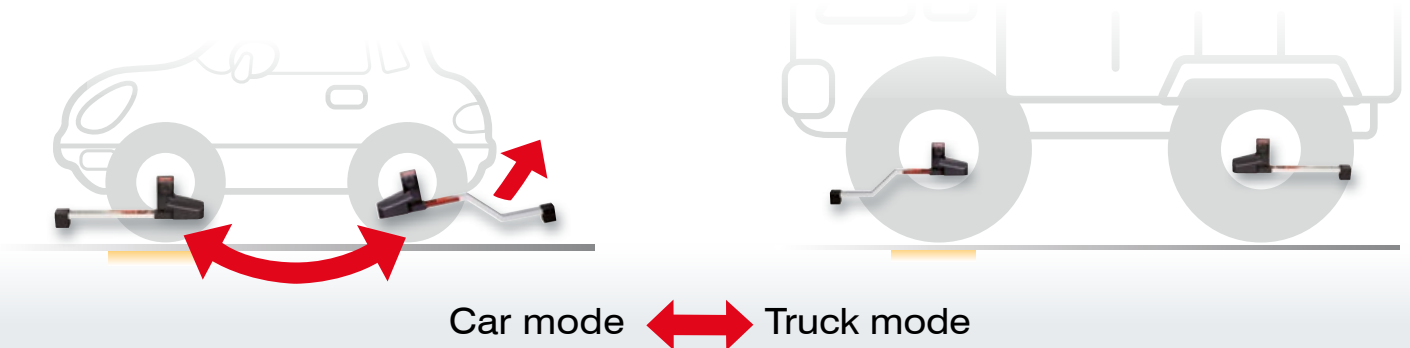

## ADVANTAGES

**LITHIUM BATTERIES:** 24 hours of work, 1 year guaranteed  
**FEATHERWEIGHT SENSORS:** 2.6 / 2.8 kg  
Immediate connection with innovative **BT<sup>2</sup> wireless communication**  
**SILICON ACCELEROMETER:** shock-proof  
**DIRECT RECHARGE OF SENSORS:** no need to disassemble them  
**SUNLIGHT FILTER:** over 12 m wheelbase even in outdoor sun exposed environment

**BESONDERS LANGE LEBENSDAUER:** 24 Arbeitsstunden, 1 Jahr Garantie  
**FEDERLEICHTE MESSKÖPFE:** nur 2.6 / 2.8 kg Gewicht  
Übertragung der Messdaten ohne Kabel mit **BT<sup>2</sup> sofortige Verbindung**  
**BESCHLEUNIGUNGSMESSER AUS SILICIUM:** schlagfest  
**DIREKTE AUFLADUNG VON SENSOREN:** kein Zeitverlust durch Demontage  
**SONNENLICHTFILTER:** keine verlängerungen mehr nötig Achsabstand über 12 m, auch im Freien und bei Sonneneinwirkung

**BATTERIE AL LITIO:** 24 ore di lavoro, garanzia 1 anno  
**RILEVATORI PESO PIUMA:** 2.6 / 2.8 kg  
Connessione immediata con l'innovativa **comunicazione senza fili BT<sup>2</sup>**  
**ACCELEROMETRO IN SILICIO:** insensibile agli urti  
**RICARICA DIRETTA DEI RILEVATORI:** nessuna necessità di smontarli  
**FILTRO SOLARE:** passo oltre 12 m anche in ambienti aperti e soleggiati

**BATERÍAS DE LITIO:** 24 horas de trabajo, garantía 1 año  
**CAPTADORES PESOS PLUMA:** 2.6 / 2.8 kg  
Conexión inmediata con la innovadora **comunicación inalámbrica BT<sup>2</sup>**  
**ACELERÓMETRO EN SILICIO:** insensible a los golpes  
**RECARGA DIRECTA DE LOS CAPTADORES:** ninguna necesidad de desmontarlos  
**FILTRO SOLAR:** paso superior a 12 m también en ambientes abiertos y asoleados

**BATTERIES AU LITHIUM:** 24 heures de travail, garantie 1 an  
**DÉTECTEURS ULTRA LÉGERS:** 2.6 / 2.8 kg seulement  
**Connexion avancée immédiate sans fils BT<sup>2</sup>**  
**ACCÉLÉROMÈTRE EN SILICIUM:** insensible aux chocs  
**RECHARGE DIRECTE DES DÉTECTEURS:** pas besoin de les désassembler  
**FILTRE DE SOLEIL:** empattement de plus de 12 m y compris à ciel ouvert et en présence de soleil

## SOFTWARE



**FAST caster swing**  
Sterzata FAST  
Braquage FAST  
Lenkeinschlag FAST  
Viraje FAST



**Adjust two axes in one screen**  
Regolazione di entrambi gli assi in un'unica schermata  
Réglage des deux essieux sur une unique page  
Einstellung beider Achse in einem einzigen Bildschirm  
Ajuste de ambos los ejes en una única pantalla

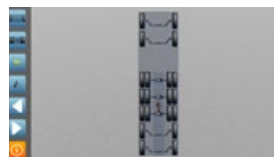

**Step by step procedure up to 7 axes**  
Procedura guidata fino a 7 assi  
Procédure pas à pas jusqu'à 7 essieux  
Schritt für Schritt-Verfahren bis zu 7 Achsen  
Procedimiento pilotado hasta 7 ejes







**2 measuring heads mode Quick measurement of front axle**  
Modalità a due sensori Misurazione rapida dell'asse anteriore  
Mode deux capteurs Mesure rapide de l'essieu avant  
Zwei-Sensoren Modus Schnelle Messung der Vorderachse  
Modalidad 2 sensores Medición rápida del eje anterior







**AUDIT function for the identification of driving problems**  
Funzione AUDIT per la diagnosi completa dei disturbi di guida  
Fonction AUDIT pour l'identification des problèmes de conduite  
Funktion AUDIT für die Diagnose der Fahrstörungen  
Función AUDIT para la identificación de problemas de conducción

## VERSIONS

### DWA1100<sup>HYBRID</sup> (with cabinet)

-  **Ergonomic design**  
**Industrial computer**  
**No moving parts more likely to break**  
**Data update through USB**
-  Design ergonomico  
Computer industriale  
Senza parti in movimento più soggette a rotture  
Aggiornamento dati via USB
-  Forme ergonomique  
Ordinateur industriel  
Sans disque en mouvement qui risquent davantage les ruptures  
Mise à jour des données via USB
-  Ergonomisches Design  
Industrieller Computer  
Ohne bewegliche Scheiben, dem stärkeren Bruch ausgesetzt sind  
Daten-Update via USB
-  Diseño ergonómico  
Ordenador industrial  
Sin partes en movimiento con más probabilidad de romperse  
Actualización datos por medio de USB

### DWA1100<sup>HYBRID</sup> Light

-  **No CABINET!** Save your working space with your laptop!
-  **Senza ARMADIO!** Risparmi spazio di lavoro ed usi il tuo pc!
-  **Sans ARMOIRE!** Gains d'espace de travail et utilisation de son propre PC!
-  **Ohne STEUERSCHRANK!** Sie sparen Raum und benutzen Ihren eigenen PC!
-  **¡Sin ARMARIO!** ¡Ahorras espacio de trabajo y utilizas tu PC!

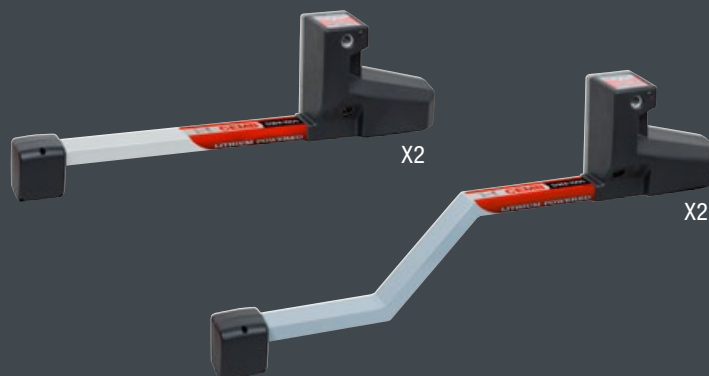

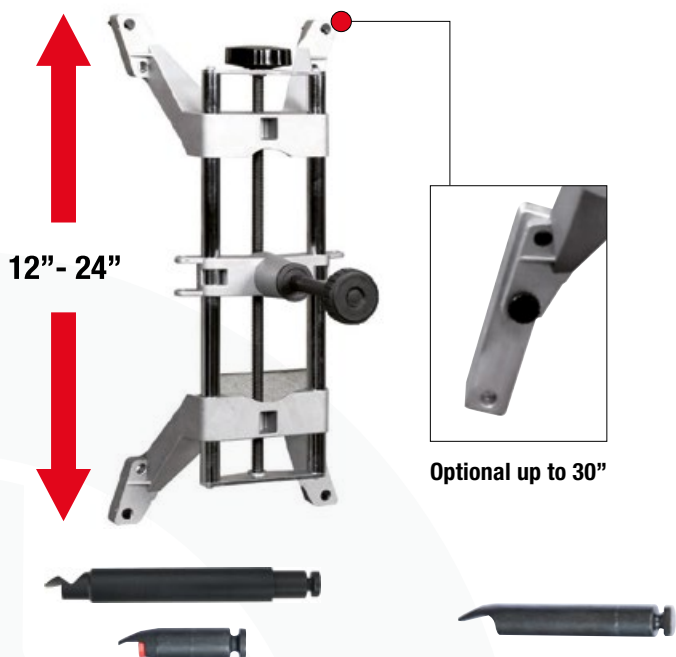

## STANDARD CONFIGURATION



 **Metal 120/48 mm grips, with reference surface, for truck and bus wheels and to optimize runout**

 Unghiette universali 120/48 mm, con piano di riferimento, per ruote di autocarro, bus e per ottimizzare il runout

 Onglets universels 120/48 mm en métal, avec surface de référence, pour roues de camion, bus et pour optimiser le runout

 Radklammerfingern aus Metall 120/48 mm, mit Auflageoberfläche, für Räder von LKWs, Bussen und zu optimieren Runout

 Uñas universales 120/48 mm en metal, con superficie de referimiento, para ruedas de camión, bus y para optimizar el runout

 **Metal 80 mm grips for 4-WD, SUV, light trucks**

 Unghiette metalliche 80 mm per 4-WD, SUV, veicoli commerciali leggeri

 Onglets 80 mm en métal, pour roues de camion, bus, 4-WD, SUV et véhicules de transport léger

 Radklammerfingern aus Metall 80 mm, für Räder von LKWs, Bussen, 4WD, SUV und Kleintransporter

 Uñas universales 80 mm en metal, para todo terreno, SUV y vehículos de transporte ligero

Optional up to 30"

## OPTIONAL ACCESSORIES



 **Clamp supporting arms and set of tips for tyres with external diameter up to 40" for CARS and up to 50" for TRUCKS**

 Bracci e gruppo di puntali per aggrappo in appoggio a pneumatici con diametro esterno fino a 40" per vettura e fino a 50" per autocarro

 Bras et groupe de broches d'accrochage en appui sur pneumatiques de diamètre externe jusqu'a 40" pour voitures et jusqu'a 50" pour camions

 Klemmarme und Positionsfinger für Radklammern zum Auflegen auf Reifen mit Aussendurchmesser bis zu 40" für PKW und bis zu 50" für LKW

 Brazos y grupo de puntales para mordaza en apoyo a neumáticos con diámetro externo hasta 40" para coche y hasta 50" para camión

**Grips for all rims and tyres are available**



 **Metal grips for clamping on steel rims from the inside**

 Unghiette in metallo per aggrappo dall'interno su cerchi in ferro

 Onglets en métal pour accrochage de l'intérieur sur jantes en fer

 Metallkrallen zum Halten von innen bei Eisenfelgen

 Uñas en metal para mordaza desde el interior en llantas en hierro

## STANDARD COMPOSITION

-  Computer with WINDOWS operating system, 27" TFT monitor, colour printer, USB keyboard, mouse (only for DWA1100<sup>HYBRID</sup>)  
Software and database for cars and trucks  
2 car sensors + 2 truck sensors  
4 clamps + safety elastic band + 3 set of grips  
Steering lock + Brake pedal lock
-  Computer con sistema operativo WINDOWS, Monitor 27" TFT, stampante a colori, tastiera USB, mouse (solo per DWA1100<sup>HYBRID</sup>)  
Software e database per auto e camion  
2 rilevatori vettura + 2 rilevatori autocarro  
4 aggrappi + elastico di sicurezza + 3 set di unghiette  
Bloccasterzo + premipedale
-  Ordinateur avec système d'exploitation WINDOWS, moniteur 27", imprimante couleur, clavier USB, souris (seulement pour DWA1100<sup>HYBRID</sup>)  
Logiciel et base de données pour voitures et camions  
2 détecteurs voiture + 2 détecteurs camion  
4 griffes + élastique de sécurité + 3 jeux d'onglets  
Blocage direction + presseur pédale
-  Computer mit Betriebssystem WINDOWS, 27"-TFT-Monitor, Farbdrucker, Tastatur USB, Mouse (nur für DWA1100<sup>HYBRID</sup>)  
Software und Datenbank für PKW und für LKW  
2 Messköpfe für LKW + 2 Messköpfe für PKW  
4 Radklammern + elastisches Schutzband + 3 Radklammerfinger  
1 Lenkradfeststeller, 1 Bremspedalfeststeller
-  Ordenador con sistema operativo WINDOWS, monitor 27" TFT, impresora de color, teclado USB, ratón (solo para DWA1100<sup>HYBRID</sup>)  
Software y base de datos para coches y camiones  
2 captadores coche + 2 captadores camión  
4 mordazas + elástico de seguridad + 3 equipos de uñas  
Dispositivo antirrobo + apretapedal

## TECHNICAL DATA

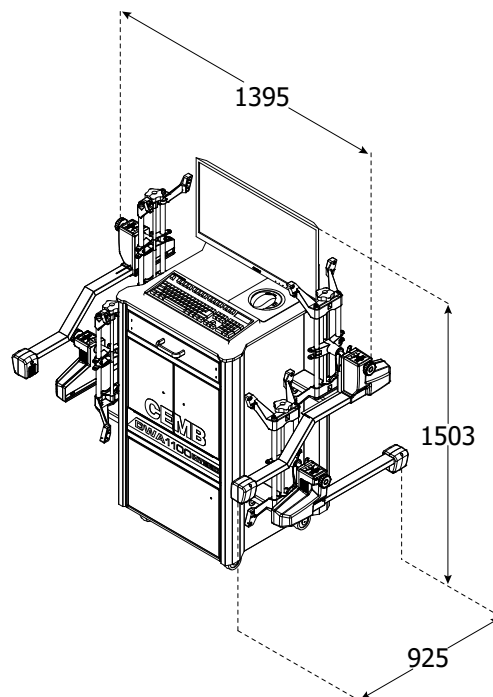

### PACKAGE DIMENSIONS AND GROSS WEIGHT:

113x113x113 cm (44,5x44,5x44,5")

220 Kg



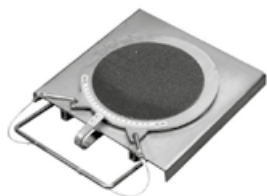

**Net weight:** 155 Kg

## OPTIONS



-  **2 mechanical turntables for cars**
-  2 piatti rotanti vettura
-  2 plateaux rotatifs véhicule
-  2 vordere Drehteller für PKW
-  2 platos rotatorios coche







-  **Premium turntables:** capacity 1000 kg per plate, Ø 35 cm, with rubber supports
-  **Piatti Premium:** portata 1000 kg per piatto, Ø 35 cm, con supporti in gomma
-  **Plateaux Premium:** portée 1000 kg par plateau, Ø 35 cm, avec supports en caoutchouc
-  **Premium-Teller:** Tragkraft 1000 kg pro Teller, Ø 35 cm, mit Auflagen aus Gummi
-  **Platos Premium:** capacidad de 1000 kg por plato, Ø 35 cm, con soportes de goma



-  **2 truck turnplates**
-  2 piatti rotanti autocarro
-  2 plateaux rotatifs pour camion
-  2 vordere Drehteller für LKW
-  2 platos rotatorios camión



-  **WiFi connection for automatic software updates**
-  Collegamento wifi per l'aggiornamento automatico del software
-  Connexion Wi-Fi pour la mise à jour du logiciel
-  Wifi-Verbindung zur automatischen Aktualisierung der Software
-  Conexión wifi para actualizar automáticamente el software



# CEMB

BALANCING MACHINES

**CEMB S.p.A.**

Via Risorgimento, 9  
23826 Mandello del Lario (LC) - Italy  
[www.cemb.com](http://www.cemb.com)



**Garage equipment division**  
**CEMB - ITALY**  
**Plant and Training Center**  
Phone +39 0341 706111  
[garage@cemb.com](mailto:garage@cemb.com)

**CEMB USA - BL Systems Inc.**  
2873 Ramsey Road  
Gainesville, GA 30501 - USA  
Phone +001 678 717 1050  
Fax +001 678 717 1056  
[sales@cemb-usa.com](mailto:sales@cemb-usa.com)

