

C330



AUTOMATIC DIGITAL BALANCER FOR TRUCK WHEELS



C330

CORE OF TECHNOLOGY

New digital wheel balancing machine suitable for truck, bus and car wheels up to 200 kg. The innovative solution of the spindle shaft that lowers, guarantees a safer and easier centring even with large wheels. The modern and attractive design, with sturdy weight-tray, improved space optimization and the wide availability of programs, make it the most complete solution in its category.

- **VDD Virtual Direct Drive** - very quick and maintenance free measurement system **CEMB PATENT**
- **Electromagnetic brake** for the lock of the wheel in the exact weight position
- Software programs for the professionals: **SPLIT, OPT, ALU**
- **Extended gauge** for diameter and distance measurement of rims up to 32"
- **ALU-S balancing mode** (adhesive weights on the internal rim planes) with specific counterweight position indicator
- **Spacious and sturdy** rotational **weight-tray** with differentiated compartments for housing cones, clip weights, alu, grippers
- **Mobile spindle shaft** for perfect centring of the wheel





LA Sonar

QUICK AND PRACTICAL MEASURING SYSTEM

LA sonar device for automatic wheel width measurement without any contact.
CEMB PATENT

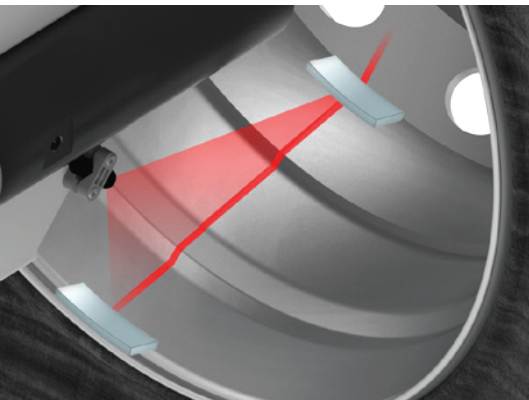

Laser Line

SOPHISTICATED RED LINE LASER INDICATOR

Laser line to facilitate the correct positioning of the adhesive counterweights in the 6 o'clock position, increasing the balancing accuracy.

LIFTING SPINDLE - INNOVATIVE WHEEL LIFT



PERFECT CENTRING, ACCURATE BALANCING!

The spindle shaft rises and lowers to facilitate wheel loading, ensuring perfect centring, ideal condition for better balancing accuracy. Loading on the ground, mount the wheel on the spindle, lift.

SAFE WHEEL CLAMPING THANKS TO THE MOBILE SPINDLE

No risk for the operator since the wheel, when raises, is already clamped on the spindle, in complete safety.

EASIER AND FASTER WHEEL HANDLING

The sliding trolley, with a height of only 59 mm, the lowest available on the market, allows a faster and easier loading of the wheel, with reduced effort for the operator.



CEMB INNOVATION

STANDARD ACCESSORIES



In 1952 Cemb created the cone adapters for balancing machines and since then the company continued developing and producing high precision centering systems for any type of wheel. **Cemb does not recommend the use of non-original adapters on its balancing machines.**

Standard equipment composed of quick nut with spacer ring, pincer-hammer, 300 g counterweight and WDC gauge



AVAILABLE ACCESSORIES - Especially designed for car manufacturers



IV/V CONES-GG-G40 KIT 41FF054929

To centre truck or bus wheels with a central hole of 202/221/281 mm Ø. Made up of IV and V cones, G40 disc and GG ring

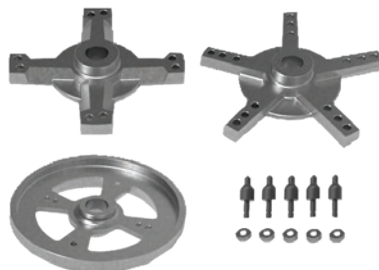

SR215 41FF67879

To centre wheels with 8 holes on 275/285.75 mm Ø and with 10 holes on 225/285.75/335 mm Ø. Supplied with centring adaptor, 5 and 4 armed spiders, stud bolts and screws

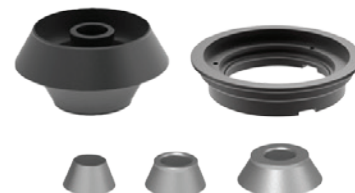

CAR ADAPTOR KIT 41FF054930

For wheels with a central hole of 45-194 mm Ø. Consists of 4 cones and G40 disc

FOR MORE INFORMATION SEE THE COMPLETE BROCHURE ON THE WEB SITE. www.cemb.com

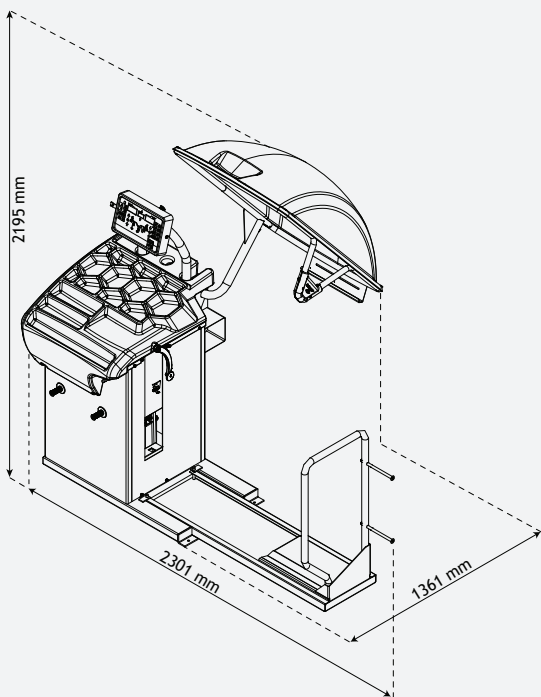

| | |
|-------------------------------------|---|
| Single phase power supply | 230V/1ph/50 hz 115V/1ph/60 Hz |
| Max. absorbed power | 1,1 kW |
| Balancing speed | 130 rpm (for car) / 80 rpm (for truck) |
| Measuring cycle for car/truck wheel | 8 ÷ 20 s |
| Measurement uncertainty | ± 0.5 g |
| Resolution | 1 g for car / 10 g for truck |
| Average noise | < 70 dB (A) |
| Rim width setting range | 1.5" ÷ 20" / 40 ÷ 510 mm |
| Rim diameter setting range | 10" ÷ 30" / 265 ÷ 765 mm |
| Min./Max. compressed air pressure | 8 ÷ 12 kg/cm ² / ~ 0.8 ÷ 1.2 MPa ~ 8 ÷ 12 bar / ~ 120 ÷ 165 psi |
| Max. wheel weight | 200 kg |
| Max. wheel diameter | 1380 mm |
| Machine weight | 230 kg |



CEMB

BALANCING MACHINES

CEMB S.p.A.

Via Risorgimento, 9
23826 Mandello del Lario (LC) - Italy
www.cemb.com



Garage equipment division
CEMB - ITALY
Plant and Training Center
Phone +39 0341 706111
garage@cemb.com

CEMB USA - BL Systems Inc.
2873 Ramsey Road
Gainesville, GA 30501 - USA
Phone +001 678 717 1050
Fax +001 678 717 1056
sales@cemb-usa.com

All the data and features mentioned in this catalogue are purely for information and do not constitute any commitment on the part of our company, which reserves the right to make any and all alterations it may consider suitable without notice.