



WHAT IF
EVERYTHING
WERE **THIS EASY?**

ER85 2-hit



SPOTTER



OPB



AutoAdaptive



CEMB

GARAGE EQUIPMENT



ER85

2-hit

UNIQUE AND REVOLUTIONARY DATA INPUT SYSTEM

- By manually moving the wheel, as shown on the monitor, **the LASER SPOTTER**, combined with a line laser, moves on the rim to measure its dimensions without using the gauge anymore. The same laser then indicates the exact point where to apply the correction weights, making the balancing process even more efficient
- **LASER MATCHING** - Line laser emitter which, together with the laser spotter, allows calculating the diameter of the rim
- **PUNCH** - The confirmation and transmission of the data acquired by the two lasers to the software occurs by lightly punching the tyre

- **OPB One Plane Balancing** - Correction of both static and dynamic unbalance on one plane at once and with only one weight
- **AutoAdaptive Mode** - The new tolerance calculation system
- **Sonar LA** for automatic measurement of the wheel width **CEMB PATENT**
- **EMS Sonar (option)** - 1st Harmonic and Peak to Peak Automatic and quick eccentricity measurement during the normal balancing cycle
- **ALU-S Balancing mode** - Adhesive weights on the internal rim planes with specific counterweight position indicator (position repeater)
- **Tyre Set** - The software indicates the best wheel positioning on the vehicle to get the best ride (conicity) and to minimize wheel vibrations (eccentricity) (option available only with EMS sonar)
- **HubMatch** - During the measuring cycle, the wheel's "maximum eccentricity point" is detected and displayed on monitor, therefore allowing for its reduction during the re-mounting of wheel on vehicle (option available only with EMS sonar)
- **Pneumatic wheel locking CEMB PATENT**
Floor to floor time reduction / Extremely easy and quick to use / Very accurate wheel centering
- **Automatic rotation and locking** of the wheel in weight position
- **Led light** to illuminate the working space inside the rim
- **VDD Virtual Direct Drive** - Very quick and maintenance free measurement system **CEMB PATENT**



Laser Spotter

PERFECT BALANCING IN JUST ONE SPIN

- Greatest accuracy in weights positioning through laser spotter.
- Preview of the exact weight positioning spot visible already during the wheel dimensions acquisition phase.
- During the correction, the **LASER SPOTTER** pinpoints the exact position for stick-on weights application inside the rim. Thanks to the electric brake, which locks the wheel into the exact angular position of the unbalance, you avoid possible errors during the weight application making the balancing process faster, simpler and more precise.
- In static balancing mode, **LASER SPOTTER** detects the exact static weight location, in order to minimize the residual unbalance on the external planes.



One Plane Balancing

WHERE INNOVATION MEETS SIMPLICITY

- **OPB** (One Plane Balancing), eliminates both static and dynamic unbalance with a single counterweight, indicating the exact position to apply the weight inside the rim. The balancer automatically detects if it is possible to correct both unbalances with only one weight and activates **OPB program**.
A real revolution in wheel balancing. **OPB** saves you time while maximizing your productivity.

CEMB extends the **2-hit** technology to a new model in the range, with the aim of offering a professional product so intuitive that it can be used by anyone. The wheel balancing process has never been easier.



CEMB PATENT

SIMPLICITY OF USE

thanks to the unique system that measures the wheel dimensions and corrects the unbalance with just two instruments

SPEED AND PRECISION

data input has never been so immediate

ERGONOMICS

the absence of the gauge allows the operator to work in better conditions of comfort and efficiency

WHAT IF EVERYTHING WERE **THIS EASY?**

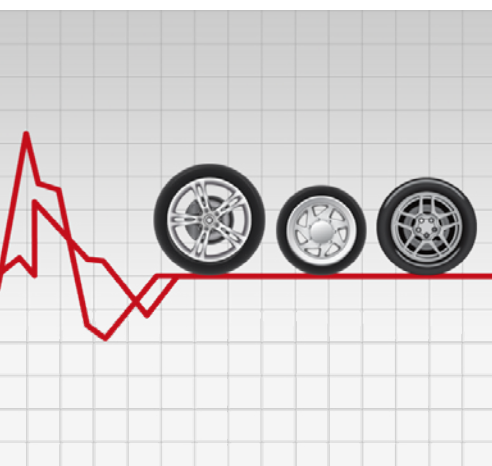

AutoAdaptive Mode

THE NEW TOLERANCE CALCULATION SYSTEM

- The innovative tolerance calculation system **AutoAdaptive Mode** is based on the evaluation of the residual imbalance limit value corresponding to an acceptable perceived vibration. For each wheel that is balanced, the software **AutoAdaptive Mode** detects weight and dimensions and calculates the tolerance value that will cancel any vibration perceived on the steering wheel. **AutoAdaptive Mode** grants the highest comfort when driving, and together with **OPB program**, saves balancing time.

STANDARD ACCESSORIES

In 1952 Cemb created the cone adapters for balancing machines and since then the company continued developing and producing high precision centering systems for any type of wheel. **Cemb does not recommend the use of non-original adapters on its balancing machines.**

UC20/SE2

composed of SE KIT, 3 CONES KIT and WIDTH GAUGE



PNEUMATIC
LOCKING



SE KIT - 41FF034417

(ring, quick locking sleeve SE2, SE spacer)



3 CONES KIT - 41FF034416

Ø 45÷110 mm, pincer-hammer and 60 g. counterweight



WIDTH GAUGE

46FC77653

Wheels with special dimensions, geometry and centring may require the use of special flanges that CEMB supplies as an option, to better meet the needs of the market. **For more information see the complete brochure on the web site: www.cemb.com**



Zero Weight /Easy Weight Lifts

OPTIONS TO REDUCE ANY EFFORT

- **PERFECT CENTERING** for a more accurate balancing
- **“ZERO WEIGHT” EFFECT** The patented system detects the weight of the wheel and cancels it automatically
- **ERGONOMICS** to minimize the effort for the operator
- **UNIVERSALS** Applicables to any CEMB balancing machine

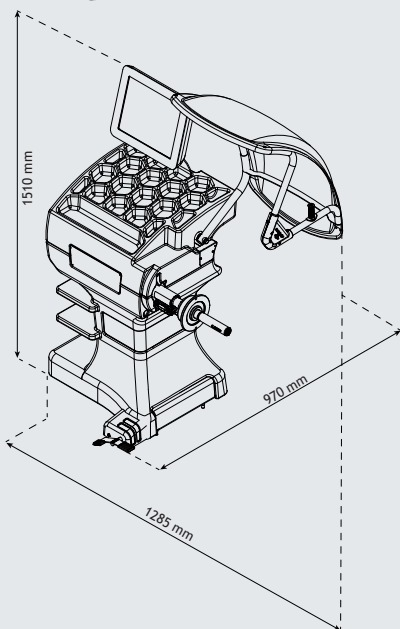

Single phase power supply	230V/1ph/50 hz
	115V/1ph/60 Hz
Max. absorbed power	0,65 kW
Balancing speed	100 rpm
Measuring cycle for 15 kg (33 lb) wheel	4.7 s
Measurement uncertainty	0,5 g
Average noise	< 70 dB (A)
Rim width setting range	1.5" ÷ 20" / 40 ÷ 510 mm
Rim diameter setting range	10" ÷ 30" / 265 ÷ 765 mm
Min./Max. compressed air pressure	7 ÷ 10 kg/cm ² / ~ 0.7 ÷ 1 MPa
	~ 7 ÷ 10 bar / ~ 105 ÷ 145 psi
Max. wheel weight	< 75 kg
Machine weight	150 kg
Package	1130x1480x1160(h) mm



CEMB
BALANCING MACHINES

CEMB S.p.A.
Via Risorgimento, 9
23826 Mandello del Lario (LC) - Italy
www.cemb.com



Garage equipment division
CEMB - ITALY
Plant and Training Center
Phone +39 0341 706111
garage@cemb.com

CEMB USA - BL Systems Inc.
2873 Ramsey Road
Gainesville, GA 30501 - USA
Phone +001 678 717 1050
Fax +001 678 717 1056
sales@cemb-usa.com

All the data and features mentioned in this catalogue are purely for information and do not constitute any commitment on the part of our company, which reserves the right to make any and all alterations it may consider suitable without notice.