

# ER95

FASTER THAN EVER



THE **FASTEST**  
FULLY AUTOMATIC  
BALANCING  
MACHINE  
IN THE WORLD



## ER95



## ER95PLUS

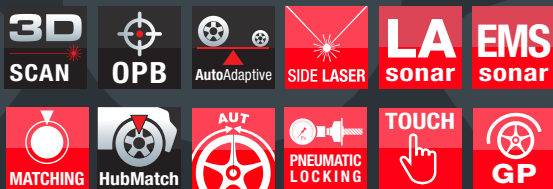

**CEMB**  
GARAGE EQUIPMENT

# ER95

- **3D Laser Scan** - Extraordinary accuracy and speed in 3D acquisition of wheel sizes with exact positioning of adhesive weights
- **Side Laser** - Line laser indicator on the upper part of the wheel to ease the application of clip-on weights in the exact position (only ER95PLUS)
- **OPB One Plane Balancing** - Correction of both static and dynamic unbalance on one plane at once and with only one weight
- **AutoAdaptive Mode** - The new tolerance calculation system
- **Sonar LA** for automatic measurement of the wheel width **CEMB PATENT**
- **EMS sonar** to measure the wheel eccentricity; through high precision sensors, it is able to detect variations in the distance between wheel centre and its external edges during rotation, allowing them to be corrected those irregularities that would make the vehicle less safe (only ER95PLUS)
- **Direct Matching** - Visualization of the best possible matching to reduce eccentricity (only ER95PLUS)
- **HubMatch®** - During the measuring cycle, the wheel's "maximum eccentricity point" is detected and displayed on monitor, therefore allowing for its reduction during the re-mounting of wheel on vehicle (only ER95PLUS)
- **Tyre Set** - The software indicates the best wheel positioning on the vehicle to get the best ride (conicity) and to minimize wheel vibrations (eccentricity) (only ER95PLUS)
- **ALU-S Balancing mode** - Adhesive weights on the internal rim planes with specific counterweight position indicator (position repeater)
- **Automatic positioning speed doubled** and instantaneous locking of the wheel at the point of weights application
- **Led light** to illuminate the working space inside the rim
- **Pneumatic wheel locking CEMB PATENT** - Floor to floor time reduction / Extremely easy and quick to use / Very accurate wheel centering

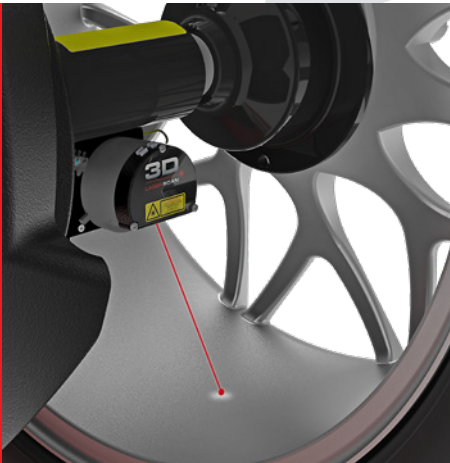

## **3D** 3D Laser Scan

**SCAN**

**EXTREME MEASURING PRECISION AND FASTER WEIGHT APPLICATION**

- Touchless wheel distance and diameter measuring system which, combined with the LA sonar for width measurement, detects with 3D precision the dimensions of any profile, even the most complex; no intervention of the operator.
- Advanced technology that speeds up the dimensions reading process without penalizing reliability and precision.
- Brighter laser pointer that grants an extreme accuracy during correction thanks to a clear indication of the application point for stick-on weights.
- Greatest robustness for a long lasting usage. No moving parts are exposed, risks of damages are reduced.
- Easy maintenance.

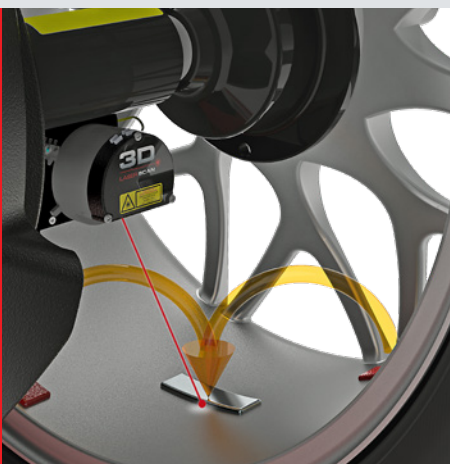

**OPB**

## **One Plane Balancing**

**WHERE INNOVATION MEETS SIMPLICITY**

- **OPB** (One Plane Balancing), eliminates both static and dynamic unbalance with a single counterweight, indicating the exact position to apply the weight inside the rim. The balancer automatically detects if it is possible to correct both unbalances with only one weight and activates **OPB** program. A real revolution in wheel balancing. **OPB** saves you time while maximizing your productivity.

# FASTER THAN EVER

# 6,4''

IN A SINGLE MEASUREMENT CYCLE:

- Automatic acquisition of wheel dimensions and correction planes
- Unbalance measurement
- Rim runout measurement
- One Plane Balancing
- Tyre runout measurement
- Direct matching
- Hubmatch®



# CEMB

INNOVATIONS

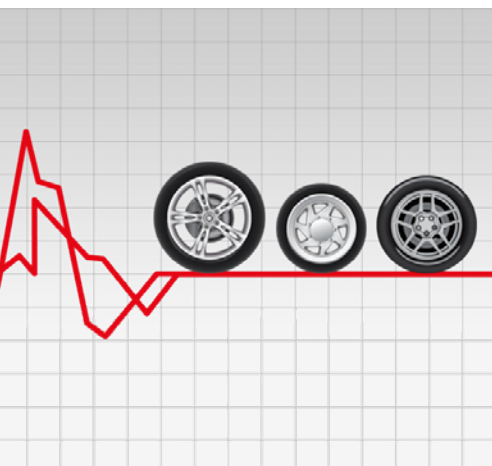

## AutoAdaptive Mode

THE NEW TOLERANCE CALCULATION SYSTEM

- The innovative tolerance calculation system **AutoAdaptive Mode** is based on the evaluation of the residual imbalance limit value corresponding to an acceptable perceived vibration. For each wheel that is balanced, the software AutoAdaptive Mode detects weight and dimensions and calculates the tolerance value that will cancel any vibration perceived on the steering wheel. AutoAdaptive Mode grants the highest comfort when driving, and together with **OPB** program, saves balancing time.

# STANDARD ACCESSORIES

In 1952 Cemb created the cone adapters for balancing machines and since then the company continued developing and producing high precision centering systems for any type of wheel. **Cemb does not recommend the use of non-original adapters on its balancing machines.**

## UC20/SE2

Composed of:  
SE kit and 4 cones Kit



**PNEUMATIC  
LOCKING**



### SE KIT - 41FF034417

Ring, quick locking sleeve SE2, SE spacer



### 4 CONES KIT - 41FF030594

Ø 45÷110 mm, pincer-hammer and 60 g counterweight/pinza-martello e contrappeso da 60 g



**46FC77653**  
Width gauge

Wheels with special dimensions, geometry and centring may require the use of special flanges that CEMB supplies as an option, to better meet the needs of the market. **For more information see the complete brochure on the web site: [www.cemb.com](http://www.cemb.com)**



## Zero Weight /Easy Weight Lifts

### OPTIONS TO REDUCE ANY EFFORT

- **PERFECT CENTERING** for a more accurate balancing
- **"ZERO WEIGHT" EFFECT** The patented system detects the weight of the wheel and cancels it automatically
- **ERGONOMICS** to minimize the effort for the operator
- **UNIVERSALS** Applicables to any CEMB balancing machine

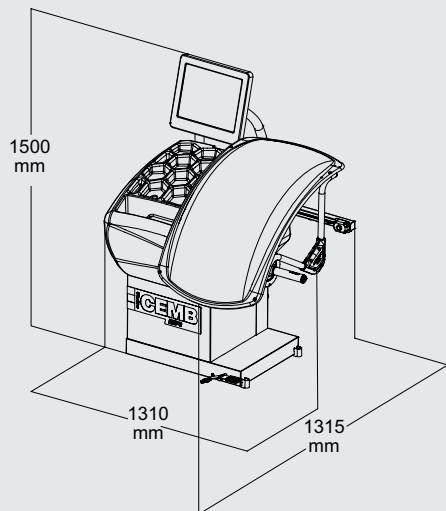

Single phase power supply

230V/1ph/50 hz

115V/1ph/60 Hz

Max. absorbed power

0,65 kW

Balancing speed

100 rpm

Measurement spin time for 15 kg (33 lb) wheel

4.7 s

Measurement uncertainty

0,5 g

Average noise

< 70 dB (A)

Rim width setting range

1.5" ÷ 20" / 40 ÷ 510 mm

Rim diameter setting range

10" ÷ 30" / 265 ÷ 765 mm

Min./Max. compressed air pressure

7 ÷ 10 kg/cm<sup>2</sup> / ~ 0.7 ÷ 1 MPa

~ 7 ÷ 10 bar / ~ 105 ÷ 145 psi

Max. wheel weight

< 75 kg

Machine weight

170 kg



# CEMB

BALANCING MACHINES

CEMB S.p.A.

Via Risorgimento, 9  
23826 Mandello del Lario (LC) - Italy  
[www.cemb.com](http://www.cemb.com)



ER95



ER96PLUS



Garage equipment division  
CEMB - ITALY  
Plant and Training Center  
Phone +39 0341 706111  
[garage@cemb.com](mailto:garage@cemb.com)

CEMB USA - BL Systems Inc.  
2873 Ramsey Road  
Gainesville, GA 30501 - USA  
Phone +001 678 717 1050  
Fax +001 678 717 1056  
[sales@cemb-usa.com](mailto:sales@cemb-usa.com)

All the data and features mentioned in this catalogue are purely for information and do not constitute any commitment on the part of our company, which reserves the right to make any and all alterations it may consider suitable without notice.